

REVISIONS				
ZONE	REV	DESCRIPTION	DATE	APPROVED

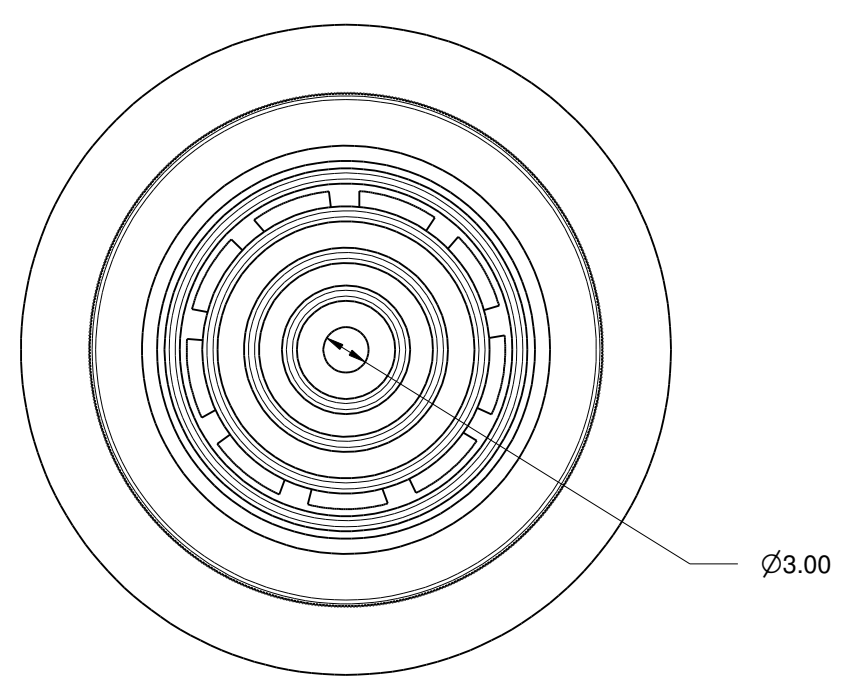

No.	Part Name	Material	Quantity
1	Case	ABS	1
2	Case	ABS	1
3	Piezo	Brass + ceramics	1
4	Transistor	Epoxy + copper	
5	Cover/PCB	Epoxy	1
6	PIN	Fe	2

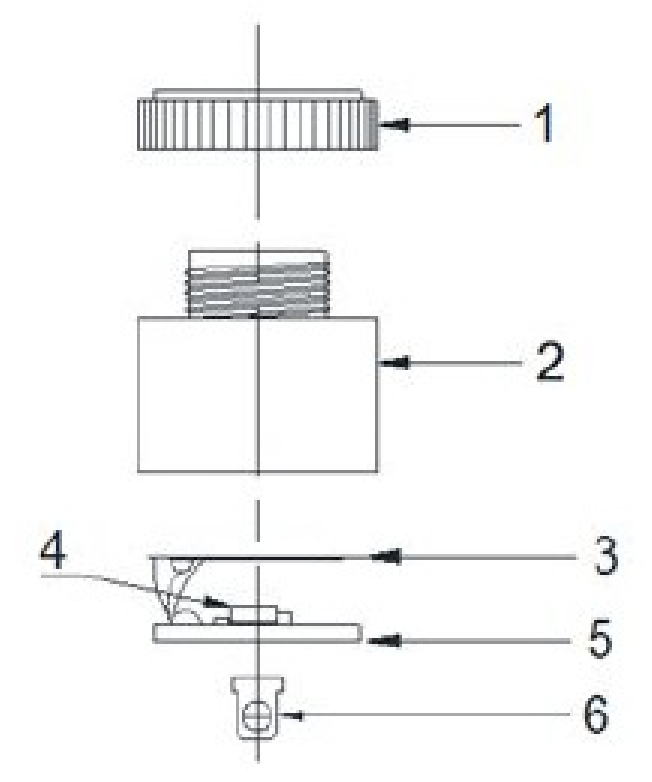
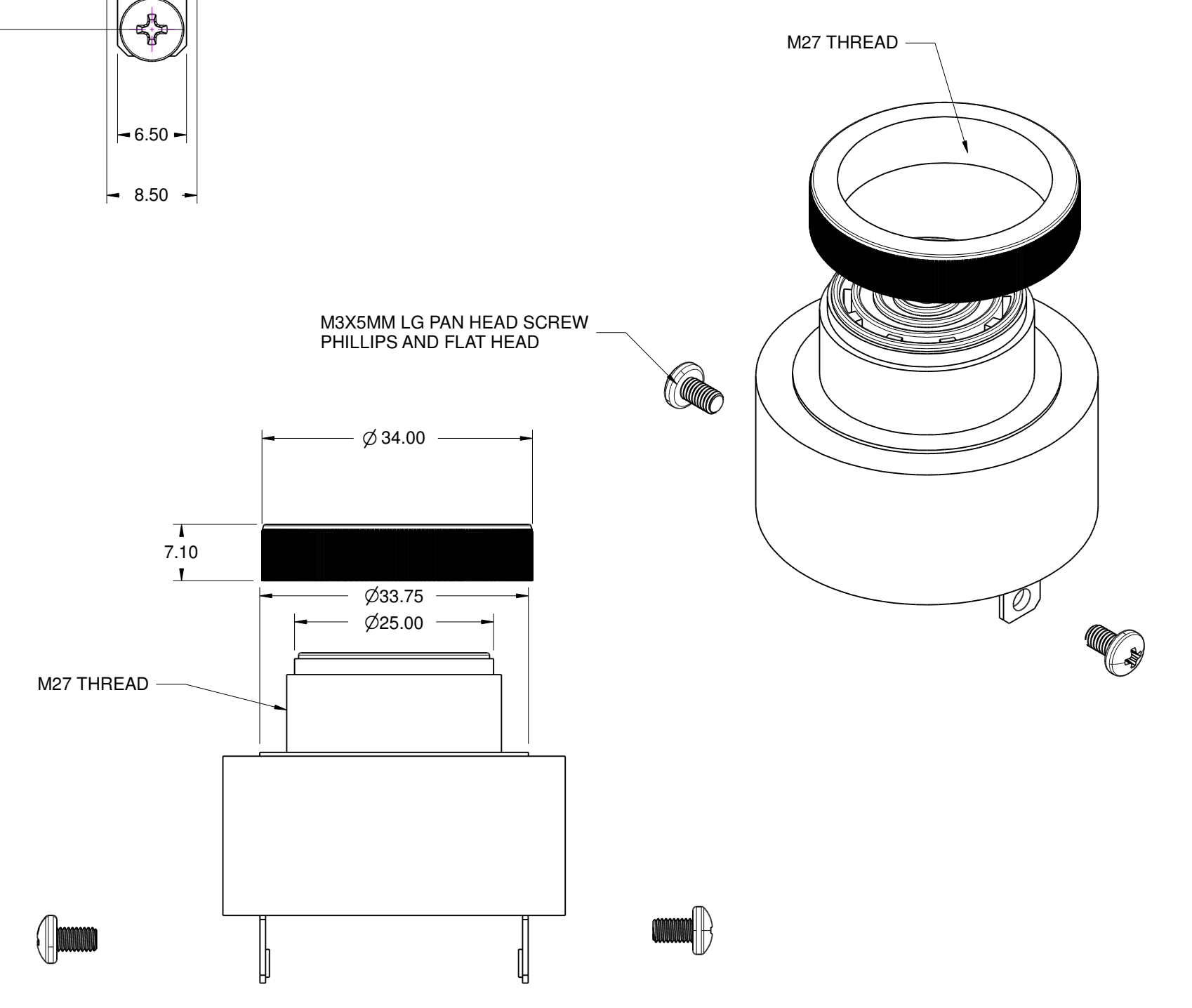
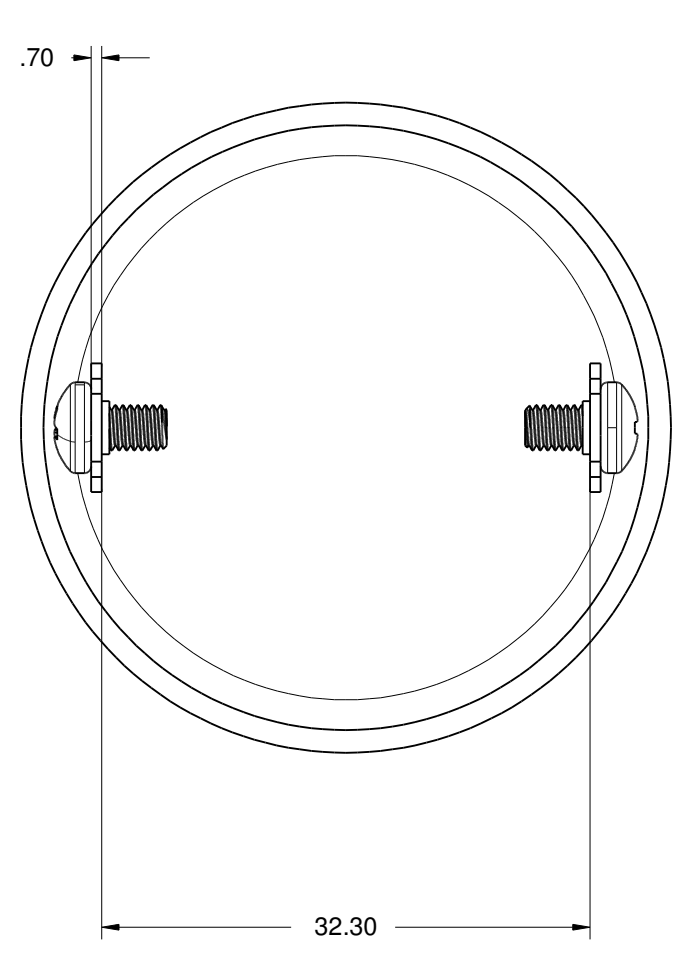
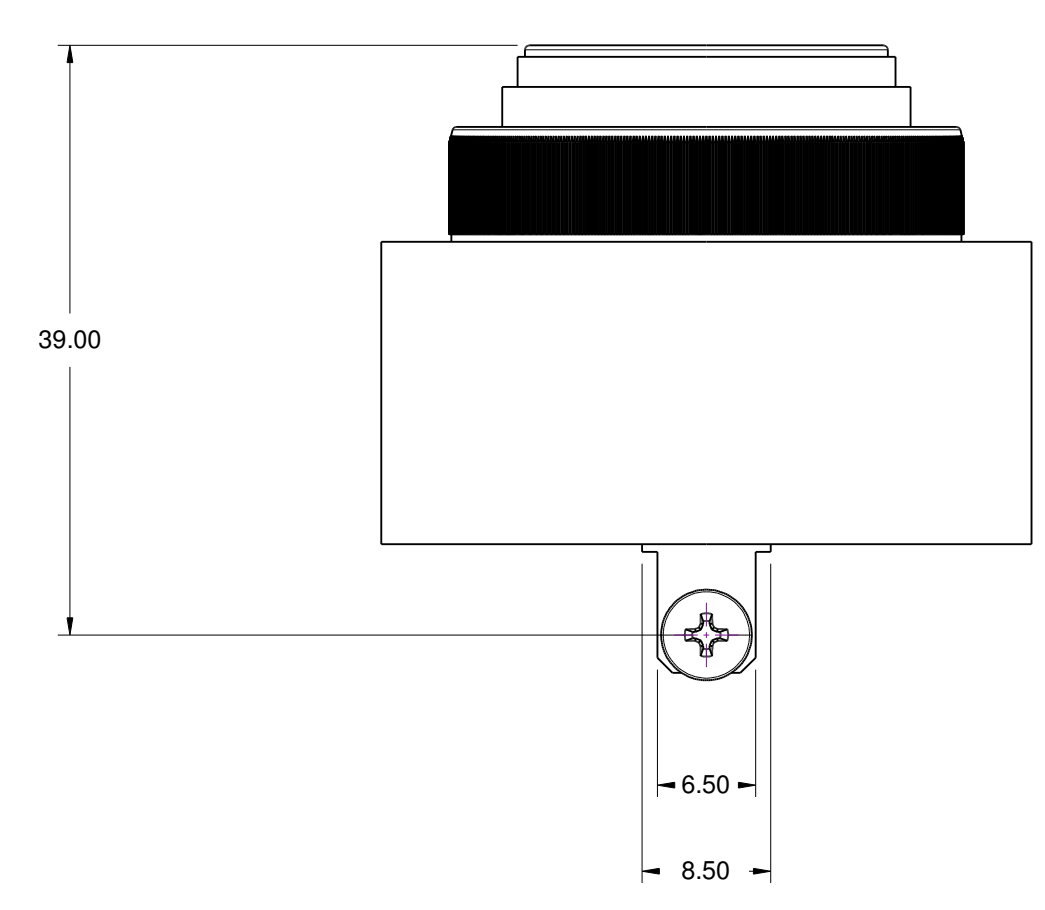
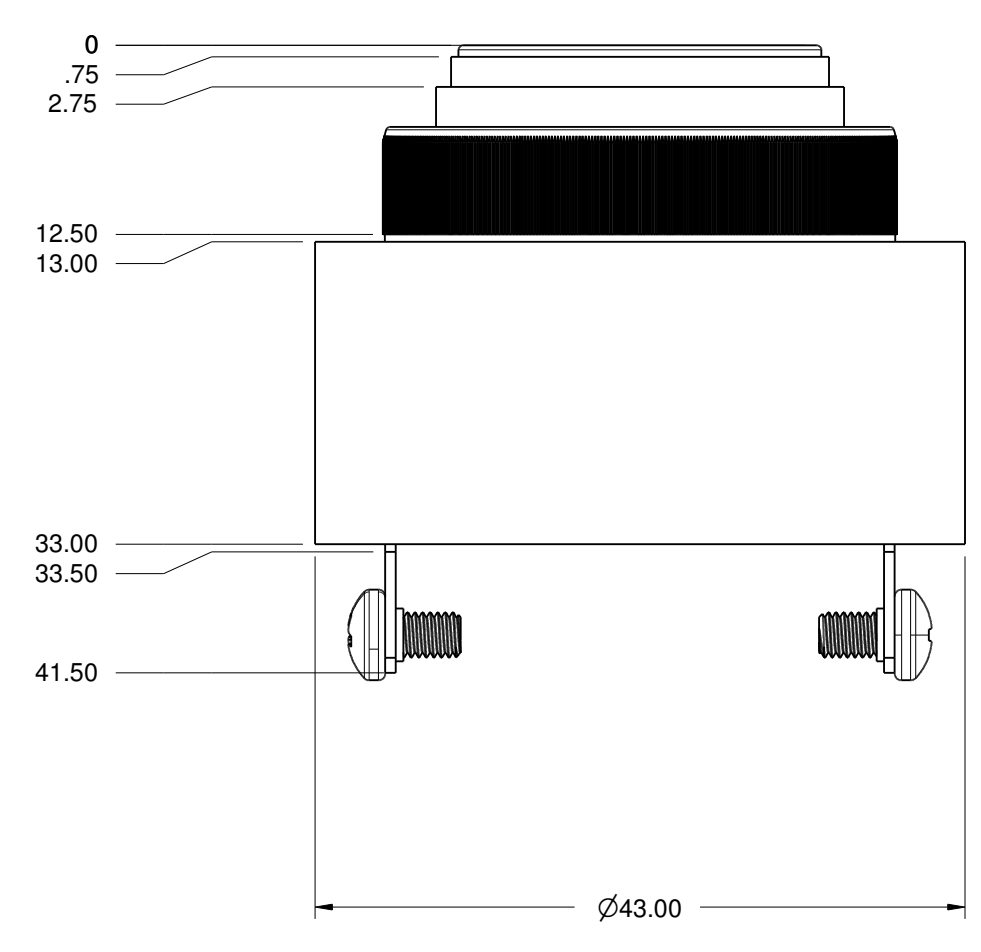
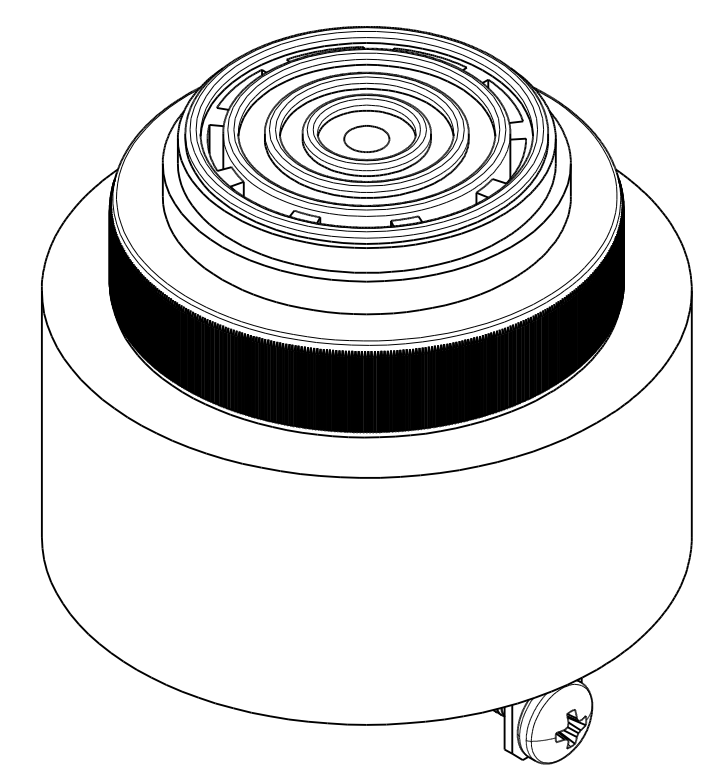

ALL TOLERANCES +/- .5MM UNLESS NOTED

SIZE	FSCM NO.	DWG NO.	REV
D		PB-4333N	
SCALE	1:1	SHEET	1 OF 1